

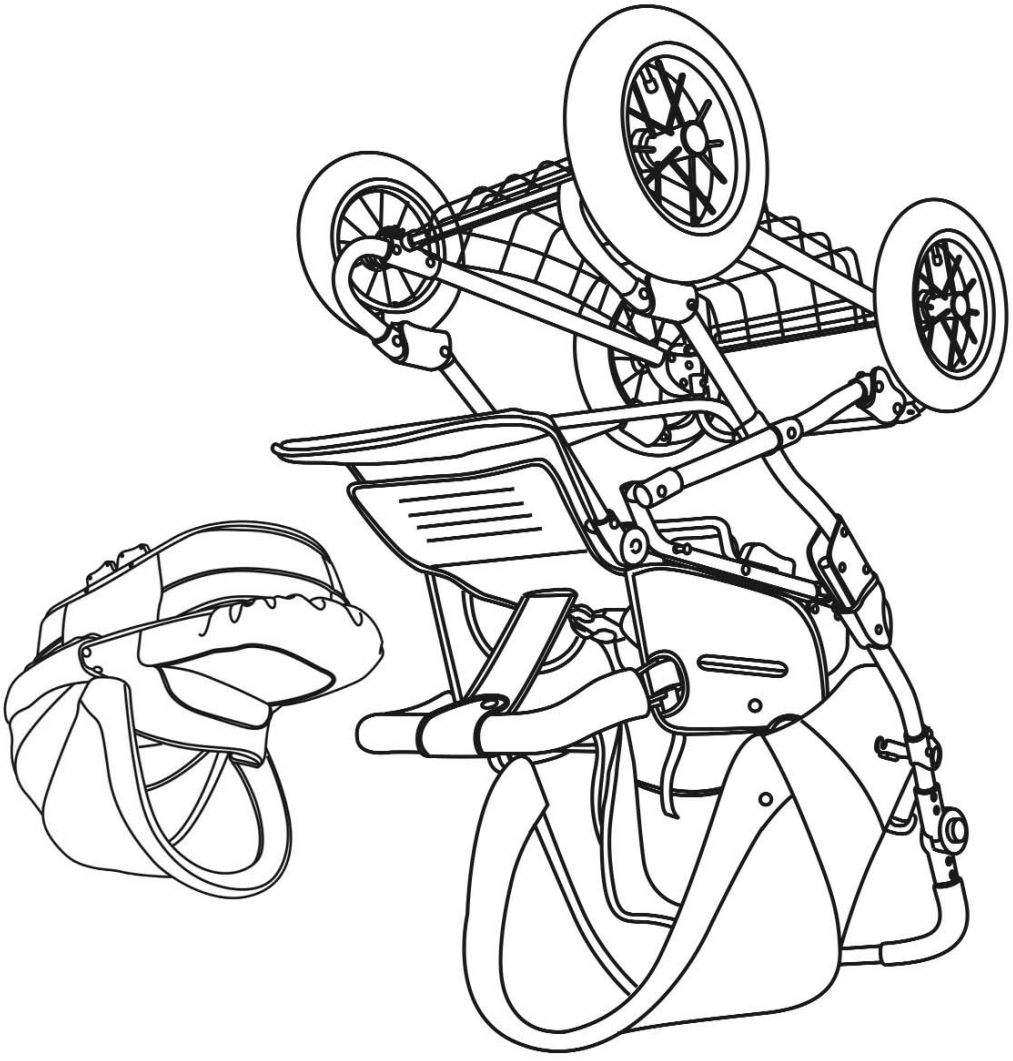

This manual applies to the following product:

### Norton Combination 3-in-1



Klieverkids Limited would like to personally thank you for purchasing our Norton products.

Enjoy!

Contact your local supplier for any queries.

**IMPORTANT TO KEEP FOR FUTURE REFERENCE**

Your Child may be harmed if you do not follow these instructions.

For the proper use of the vehicle, be sure to read this user manual carefully.

This product complies with BS EN1888: 2003



**TABLE OF CONTENTS**

Contents of the box ..... 1

Original Norton Accessories ..... 1

Pram and Stroller Parts ..... 2, 3

Important safety information ..... 4

Assembly of the Carrycot ..... 5

How to use the Carrycot (functions) ..... 5

Assembly of the chassis ..... 6

How to use the chassis ..... 7

Assembly of seat unit ..... 7

How to use the vehicle ..... 7, 8

Care and maintenance ..... 9, 10

Please note the term Vehicle is used for "wheeled child conveyance"

**BOX CONTENTS**  
**Norton 3 in 1 Combination**

1 pc seat unit including fabric and five point harness  
1 pc folded chassis with tray

4 pcs wheels

1 pc instruction manual

1 pc raincover

1 pc mattress

1 pc carrycot

1 pc carrycot liner

1 pc hood (extendable for the seat unit)

1 pc footrest fabric

1 pc seat unit apron (extendable)

1 pc carrycot apron

1 pc bumper bar with cover

1 pc PVC

1 pc deluxe changing bag

1 pc deluxe footmuff fleece lined.

**Washing Instructions**

● **Hood**

Take off and extend the hood. Shower the hood from the inside (Interior Fabric) with luke warm water. Use mild liquid soap as detergent. Cleanse it thoroughly. Drip dry the hood fully extended.

● **Seat Unit and 5 point harness**

Remove the seat fabric from the chassis. Hand wash seat fabric in luke warm water. Use mild liquid soap as detergent. Cleanse thoroughly. Drip dry the seat fabric. When the seat fabric is removed the 5 point harness is accessible. Only wipe the nylon straps and plastic parts clean with a damp cloth. Do not hand wash. Make sure the harness is dry before re-assembly.

● **Front bar cover (bumper bar)**

Remove the front bar cover. Hand wash in luke warm water. Use mild soap as detergent on the surface of the exterior fabric. Handle non-woven interior material with care. Drip dry.

● **Removable inner fabric and mattress**

Hand wash is strongly recommended. Handle all non woven material with care. Drip dry.

● **Carrycot**

Remove the Hood and the bed liner, mattress and apron. Wipe the exterior fabric and the interior nonwoven material, clean with a damp cloth. Do not hand wash. Dry the pram body in its fully extended position. Make sure the wooden base is protected from any water.

● You may apply a material protector (like Scotch guard TM) on the exterior fabric after washing. Always apply before re-assembly.

**WARNING:**

Do not place child / children in stroller for at least 24 hours after applying a material protector.

Please make sure all parts are assembled correctly according to the instructions in this manual.

## CARE AND MAINTENANCE

General care and maintenance instructions:

- Never expose your vehicle to excessive sunlight for long periods of time.
- Always use a raincover when it's snowing or raining.
- Never store your vehicle in cold and / or damp places
- Should the chassis become wet, dry it off promptly. Make sure the vehicle is completely dry before storage.
- If the vehicle particularly chromed has been used near the ocean or the salted roads. Spray the chassis with a hose and dry.
- Be careful during transportation and storage as the surface of the chassis is fragile. Scratches and dents that arise after the sale are not a justifiable complaint.

Inspect your product routinely:

- Regularly clean the chassis and metal parts of the vehicle dry off the chassis and lubricate all joints of the chassis.
- Spokes, and fenders on all wheels, should frequently be wiped off with a dry cloth. When the pram has been used during the winter time. Cleaning should take place at least once a week.

- Lack of this maintenance could cause corrosion on the spokes and fenders. If corrosion on the surface should occur which is a possibility, you are required to remove this with a corrosion cleaning agent.
- It is recommended to lubricate the wheel axles and the suspension system every three (3) months. Axles may be lubricated with petroleum jelly or automobile oil.

Check that:

- All chassis locking devices are functioning properly
- All rivets, nuts and bolts are firmly tightened and not broken.
- All plastic parts are not cracked or broken.
- The wheel bushings are in a good condition.
- All Velcro's are securely fastened on backrest pocket and seat board flap
- The press-stud is securely fastened on the footrest flap.
- The brake is operating correctly
- The tyre air pressure is correct.

Please observe:

- When in need of servicing with original parts and other technical issues that require a professional decision, ALWAYS GET IN TOUCH WITH YOUR RETAILER where you purchased your Norton product. All Norton products come with a 6 month manufacturing guarantee. This guarantee does not apply when issues arise through normal wear and tear.
- This information is relevant for Great Britain only.

**WARNING:**

- Tyres can when in contact with PVC flooring or other plastic materials cause discolouration. Always use wheel protection if the pram/stroller is stored on delicate surfaces.

## PRAM AND STROLLER PARTS

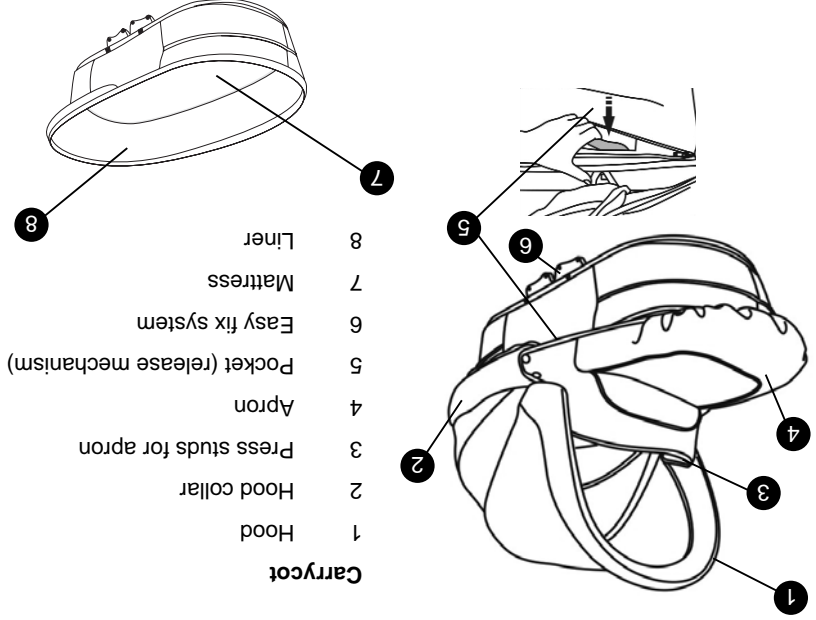

- Carrycot**
- 1 Hood
  - 2 Hood collar
  - 3 Press studs for apron
  - 4 Apron
  - 5 Pocket (release mechanism)
  - 6 Easy fix system
  - 7 Mattress
  - 8 Liner
- Chassis**
- 9 Adjustable handle
  - 10 Locking clip
  - 11 Easy fix housing
  - 12 Parking device- foot brake
  - 13 Wheel hub
  - 14 Shopping tray

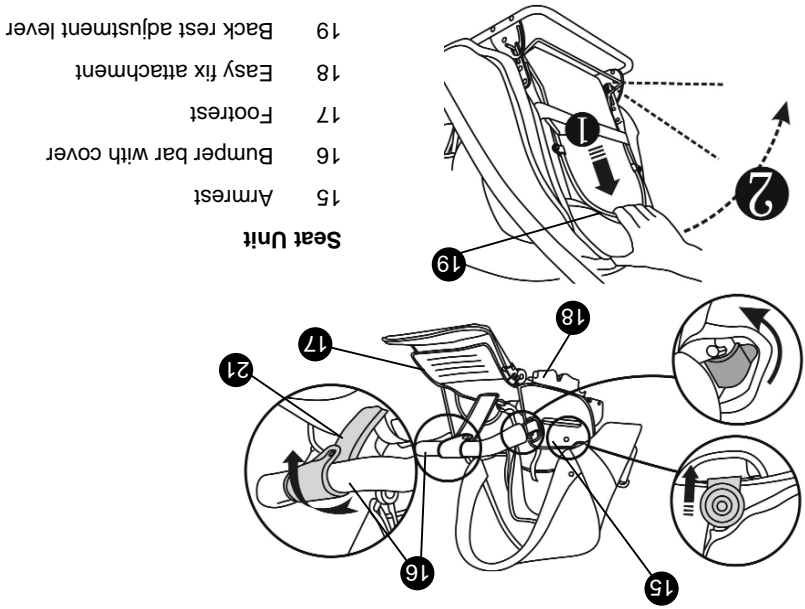
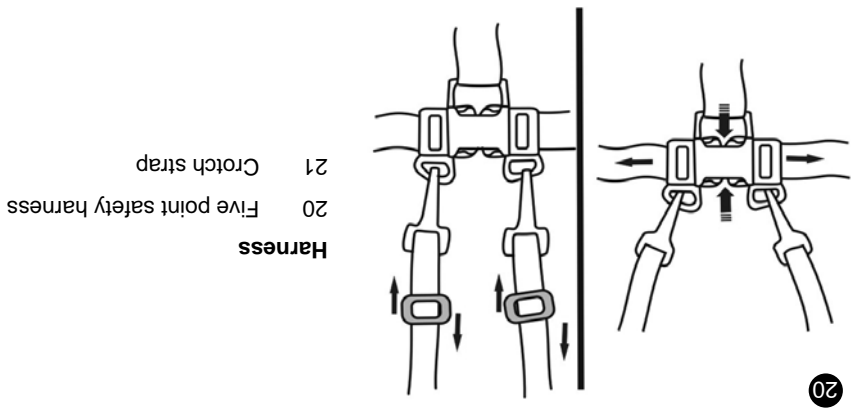

Use of the raincover

The raincover is attached by placing the raincover over the carrycot and seat unit. Please note use the raincover that has been supplied with the pram.

Always use the raincover when it is raining or snowing. If the pram is damp prior to affixing the raincover please wipe dry before attaching.

Make sure the raincover is completely dry before it is placed back into storage.

**WARNING:** Never let your children stand on the footrest.

Make sure the footrest is locked into the position before usage.

To raise the footrest pull the footrest into the desired position.

Adjusting the footrest, this can be adjusted into 2 positions. To lower the footrest press the buttons either side of the footrest to lower.

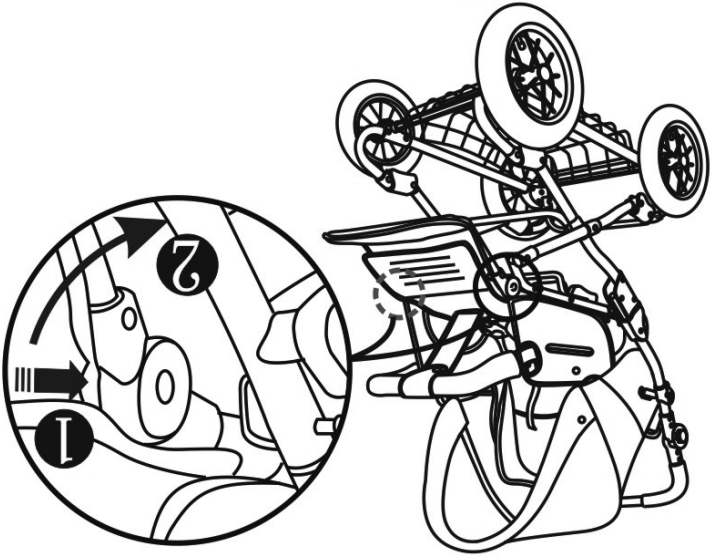

## HOW TO USE THE CHASSIS

Engage the parking device.  
Engage the parking device by pushing down with your foot.  
Disengage the parking device by pulling up.

**WARNING:**  
Never leave the vehicle without first engaging the parking device.  
The prams parking device should always be engaged when you lift your child in and out of the pram.  
Avoid uphill and downhill parking.  
Models with cog brakes: Ensure that the brake pin is firmly secured in the wheels cog brakes when the vehicles brake is engaged.

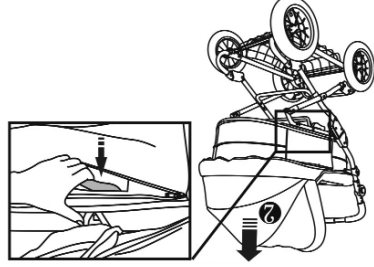

Assembling  
Engage the parking device. Hold onto both of the handles, which are located behind the zipped pockets on both sides of the seat and carrycot. Fix both sides until there is the noise of a definite click and the unit has been safely located.

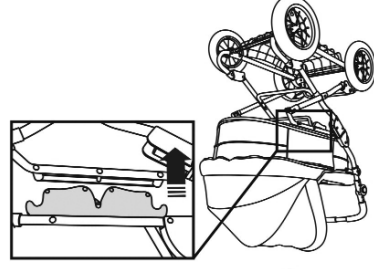

## ASSEMBLING AND RELEASING THE SEAT UNIT AND CARRYCOT

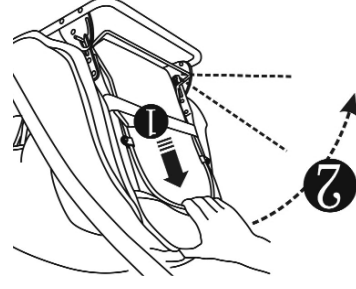

Adjusting the back rest  
Raising and lowering the backrest.  
Raise the backrest into the desired position by pushing it forward.  
Lowering the backrest pull the backrest lever as shown in the diagram and lower the backrest to the desired position.  
**WARNING:**  
Once the desired position is set push down on the backrest to ensure that it is locked into the desired position.

## IMPORTANT SAFETY INFORMATION

Please read the following **WARNINGS** and **IMPORTANT INSTRUCTIONS** carefully before use. Keep this manual for future reference.  
**WARNING:** Information that may involve the safety of the children/child.  
**IMPORTANT:** Miscellaneous information (including instructions) to help make vehicle maintenance easier.

**WARNING:**  
**FAILURE TO FOLLOW THE PROPER USAGE OR THE ASSEMBLY INSTRUCTIONS MAY CAUSE SERIOUS INJURY TO YOUR CHILD/CHILDREN AND/OR CAUSE DAMAGE TO THE CONSTRUCTION OF THE VEHICLE.**

Read these instructions carefully before use and keep them for future reference. Your child's safety may be affected if you do not follow these instructions.

**WARNING!** It may be dangerous to leave your child unattended.  
**WARNING!** Ensure that all the locking devices are engaged before use.  
**WARNING!** Use a harness as soon as your child can sit unattended.

**WARNING!** This seat unit is not suitable for children under 6 months.

**WARNING!** Any load attached to the handle affects the stability of the pram/pushchair.  
**WARNING!** This product is not suitable for running or skating.

**WARNING!** Always use the crotch strap in combination with the waist belt.  
**WARNING!** Check that the pram body or seat unit attachment devices are correctly engaged before use.

**WARNING!** Do not add a mattress thicker than 25mm in the carrycot part.  
**WARNING!** Accessories and spare parts that the manufacturer has not approved cannot be used.

The carrycot is for a child in the age group of 0 months to 9 months.  
The seat unit has been designed for the use of one child from 6 months up to a weight of maximum 15kg.

Make sure the child is safely secured with the harness.  
The safety of your child is your responsibility

The safeguards and instructions in this manual cannot cover all possible conditions and unforeseeable situations which may occur. It must be understood that common sense, caution and care are factors which cannot be built into this product. These factors must be supplied by the person(s) caring for and operating the vehicle.  
It is **IMPORTANT** that these instructions are understood by all people who will use the vehicle and accessories. Always inform and instruct each person using the vehicle and accessories as to how this product should be used, even if the person will only use this for a short while. If any instructions are unclear and need further explanation or if you have any further questions please contact an authorised **NORTON** retailer.

The depth of the top of the mattress to the top of the body at, or any position within 300mm from the harness attachment points should not be reduced to less than 150mm when the mattress is in position. Only use a mattress with a thickness of maximum 25mm in the carrycot part.  
Seat part or pram body may not be used as a car seat.  
This vehicle is made for transportation only. Never use this vehicle as a bed for your child/children.

Always store the pram away from children and do not allow children to play with it or in it.  
A separate harness, if used, must comply to BS6684  
seat.  
Make sure the harness waist straps are securely fastened to the "D" rings on each side of the

Never leave this vehicle without first engaging the parking device.  
The parking device should always be engaged while placing and removing your child/children from the vehicle.

Avoid parking on a hill.

For safety reasons, please only use Norton's accessories.

Overloading, incorrect folding and the use of non approved accessories may cause injury to your child/children and damage or break this vehicle.

Never leave this vehicle in a dangerous location, even when not occupied.

Do not hang any load on the handle as this affect the stability of the vehicle.

Never place any load on the hood of the vehicle.

The shopping tray included with the chassis has a weight limit of 5kg. Always place heavy items in the centre of the tray. This may affect the stability of the vehicle if the weight is unevenly distributed in the tray.

Items in the shopping tray must not protrude so goods get caught in the wheel spokes.

Air tyres - please make sure the top of the air regulator is correctly tightened.

It may be unsafe to use replacement parts other than those supplied by Kievertids limited.  
Follow care and maintenance instructions.

## ASSEMBLY OF THE CARRYCOT

Discard all the plastic covers from the packaging  
Slide the two metal support brackets onto the base of the pram body.

### WARNING:

Choking hazard. Keep plastic covers away from children  
Make sure the metal brackets have been securely fastened

Fold the interior liner around the rim of the carrycot

Make sure the trimmed holes on each side of the lining are threaded around the plastic holders.

Insert the mattress.

The depth of the top of the mattress or other bed accessories, to the top of the side of the carrycot should not be less than 150mm when the mattress is in position. Only use mattresses with a thickness of maximum of 25mm.

Attach the hood to the pram body by pushing the plastic leg of the hood into the plastic holders on the pram body.

Press the hood fabric onto the carrycot using the poppers provided.

### WARNING:

The pram is delivered with a hood and it must always be assembled when the pram is in use.

Press the apron onto the outside of the hood with poppers provided.

5

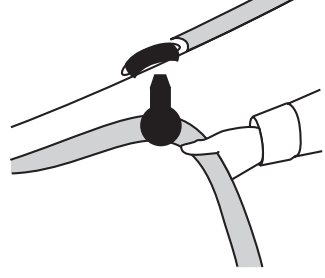

## ASSEMBLY OF THE CLASSIC CHASSIS

Release the storage clip to open the chassis until it is fully unfolded.

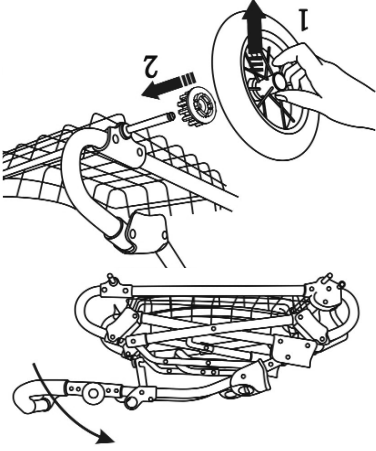

Assemble wheels with brake cogs onto axle as shown.

The safety catch will become engaged only if the main locking devices are not correctly in position. This is to prevent accidental folding.

### WARNING:

Always check that the main locking devices are engaged correctly before using your pram, it is dangerous to use your vehicle without these in their correct position.

How to adjust the handle

Adjust the handle by pressing the buttons on the side of the handle simultaneously.

Without releasing the buttons adjust the handles upwards or downwards to the desired position.

Models with air tyres

If you need to inflate your tyres, use an air pump with an adaptor for cars.

For correct pressure see tyre.

The tyres are assembled by hand. If the pram rolls unevenly, this can easily be adjusted (deflate the tyres a little and pull the tyre into the correct position).

Please note\* through depletion of the Ozone layer and an increase in the UV radiation, the tyres get small dry cracks appearing. This does not affect the driving of the Norton products and Kievertids limited will not be responsible for complaints from this matter.

### WARNING:

To avoid a puncture, don't drive over sharp edges or broken glass.

To achieve optimal driving conditions and to avoid a flat tyre, the air pressure should be correct. Please check the air pressure on a frequent basis.

6